

# High Performance Power Line Filters



**MIPE**  
L I M I T E D

# High Performance Power Line Filters

This catalogue details high performance low pass power line filters in current ratings from 5A to 2400A.

Specifically designed by MPE to offer the highest possible performance in a given package size, these filters are suitable for a wide variety of applications.

In addition to our well known single and three phase designs, new filter ranges are included for more specialised applications. These new ranges include d.c. power line filters and single line filter designs in compact tubular and rectangular case styles.

The technical notes on the following pages should be consulted for detailed information on different types of filters and their applications. A brief summary of selection criteria is given below, and a more detailed application guide is given on page 2.

- For most single and three phase mains applications, the ideal filter choice should be a multiple line filter incorporating current compensating inductors.
- Where enhanced safety and leakage current are major considerations on single and three phase mains applications, the best choice is a low leakage filter incorporating current compensating inductors.
- Where single a.c. lines such as control lines need filtering then a single line a.c. filter design should be used.
- For two line d.c. filtering with return current flowing through the filter, then a d.c. filter incorporating current compensating inductors is the best choice.
- For single line d.c. filtering of supplies using an earth return, a single line d.c. filter should be used.

A comprehensive product support service is available on our technical helpline.

**MPE Technical Helpline: +44 (0) 151 632 9199**

# MPE Power Line Filter Application Guide

Applications	DC Filters			AC Filters								
	Single Line DC (Tubular Case)	Single Line DC	Two Line DC	Single Line AC (Tubular Case)	Single Line AC	Standard Range 1 & 3 phase	Extended Performance 1 & 3 phase	Low Leakage Performance 1 & 3 Phase	Low Leakage Extended Performance 1 & 3 Phase	"2 Phase"	400Hz 1 & 3 Phase	800A - 2400A
Page Number of Filter Range	10	12	14	16	18	20	22	24	26	28	30	32
Single line d.c. supplies	●	●		◇	◇							
Two line d.c. supplies (with load current returning through filter)	◇	◇	●				◇	◇				
Single line a.c. supplies				●	●							
Single phase plus neutral supplies				◇	◇	●	●					
Single phase plus neutral supplies with low leakage requirement								●	●			
Three phase supplies with or without neutral				◇	◇	●	●					●
Three phase plus neutral supplies with low leakage requirement								●	●			●
Balanced single phase supplies (no neutral) & two phase supplies				◇	◇					●		
400Hz supplies											●	
Three phase supplies - very high current (800A-2400A)												●

● = Best Option

◇ = Alternative

# Contents

Page No.	Contents/ Filter Range	Voltage Rating	Current Rating	100dB Insertion loss from
4	MPE Limited	-	-	-
5	Technical Information	-	-	-
10	Single Line DC (Tubular Cases)	250V DC	6 - 200A	80kHz 200kHz 500kHz
12	Single Line DC (Rectangular Cases)	250V DC	5 - 200A	10kHz
14	Two Line DC	250V DC	5 - 200A	10kHz
16	Single Line AC (Tubular Cases)	250V AC	6 - 200A	350kHz 900kHz 2MHz
18	Single Line AC (Rectangular Cases)	250V AC	5 - 200A	14kHz
20	Standard Range (1 & 3 Phase)	250/440V AC	5 - 400A	10kHz 50kHz 100kHz
22	Extended Performance (1 & 3 Phase)	250/440V AC	6 - 400A	10kHz
24	Low Leakage (1 & 3 Phase)	250/440V AC	5 - 400A	50kHz 100kHz
26	Low Leakage Extended Performance (1 & 3 Phase)	250/440V AC	5 - 400A	10kHz
28	"2 Phase" Range	250/440V AC	5 - 400A	50kHz 100kHz
30	400Hz Range (1 & 3 Phase)	115/200V AC 400Hz	5 - 200A	100kHz
32	Very High Current (3 Phase)	250/440V AC	800 - 2400A	10kHz 100kHz
36	Fixing Kits	-	-	-
37	Installation Details	-	-	-
38	Outline Dimensions	-	-	-
40	Custom Designs	-	-	-

## Introduction

MPE's reputation as one of Europe's leading filter specialists is based on over 65 years experience in the design, development and production of high performance radio frequency interference filters and custom capacitors. Our commitment to a policy of continuous product development and innovation has resulted in one of the most comprehensive ranges of filter products available from a single manufacturer.

The latest filter technology has been developed and adapted to new requirements by maintaining continuous close liaison with Government Agencies and Defence Contractors, both in the UK and abroad. Our unrivalled capability and experience enables us to design and build filters and systems to suit almost any application.

In addition to the power line filters covered by this catalogue, standard products manufactured by MPE range from sub-miniature ceramic filter pins for avionics and missile systems, through precision filters for telephone and data lines to high voltage X-ray capacitors tested to 200,000 volts.

Non-standard requirements can be fulfilled by a custom designed filter or capacitor from a very diverse range and capability also offered by MPE.

To complement our filter products, we can also supply fixing kits, RFI trunking and shielded termination enclosures. Full installation and site testing services are available

Complete turnkey systems with welded or modular shielded rooms can also be supplied.

## Approvals

Apart from many individual vendor approvals, MPE holds the following major factory accreditations:

- NATO AQAP-1
- BS5750 Part 1/ISO9001/EN29001
- BS9000/CECC
- Member of Industrial TEMPEST Scheme

Numerous product approvals and registrations include:

- British Telecom Approvals for Telephone Filters
- BS9000 Product Approvals

- Defence Standard Approvals
- NATO Stock Number Listings
- FV (Fighting Vehicle) registered designs
- TEMPEST recommended products
- EMP type-tested systems

## Manufacturing Capability

Strict control over critical processes is maintained by carrying out all manufacturing operations ourselves at our Liverpool factory. This also ensures maximum flexibility for producing custom designs. Special environmentally controlled production areas are dedicated to the manufacture of capacitors and inductors.

We also have dedicated areas for sub-assembly manufacture, electroplating, oil purification and vacuum impregnation, resin encapsulation, paint finishing, and high voltage testing.

## Design and Development

Members of our design team are always available to offer technical support and can visit your premises, if required, to discuss project requirements at an early stage.

Extensive use is made of computer aided capacitor and filter design techniques and circuit modelling programs. Theoretical performance is always validated by prototype testing.

Diagnostic EMC analysis of your equipment can be carried out in our screened room installation to provide cost effective filter solutions based on our extensive design experience.

The development test laboratory is well equipped with specialist facilities and is capable of carrying out a variety of special tests including high energy EMP pulse injection testing.

## Quality

All products are 100% tested under AQAP-1 conditions prior to leaving our factory. Product quality is continuously monitored through the use of MPE's environmental test laboratory which operates under the direct control of the quality manager.

Together with our fully equipped RFI test facilities, this enables us to undertake complete type test approval programmes to both military and commercial specifications.

## Terminology

**RFI:** Radio Frequency Interference.  
Traditionally considered to cover the radio spectrum 150kHz - 300MHz.

**EMI:** Electro Magnetic Interference.  
A more modern term to cover typically 10kHz - 10GHz.

**EMC:** Electro Magnetic Compatibility.  
The ability of equipments and systems to function as designed in an electromagnetic environment.

**EMP/NEMP:** (Nuclear) Electromagnetic Pulse.  
Generated by a nuclear explosion, EMP is a high energy pulse capable of damaging most types of unprotected electronic equipment.

**TEMPEST:** This refers to the need to prevent equipment from generating conducted or radiated EMI which could contain intelligible information.

## Application Information

### RFI/EMI/EMC

All filters in this catalogue have wide application in the EMC field where high performance is required. They are ideal for filtering d.c. and a.c. mains services to screened enclosures against both incoming and outgoing noise and transients. They are equally suitable for the protection of permanently wired equipment such as computer installations.

With the increasing importance of filtering down to low frequencies, it should be noted that many of the filter ranges within this catalogue will offer 100dB performance even down to 10kHz.

### EMP Protection Systems

EMP protection systems normally comprise a primary protection component, a delay element, a secondary protector, and a filter.

Most filters in this catalogue, by virtue of their performance, are ideally suited for use in such systems. Many of the ranges will meet the new stringent insertion loss requirements demanded by MIL-STD 188-125 i.e. 100dB from 14kHz to 1 GHz. Transient suppressed versions of filters should be selected for use in EMP protection systems as they incorporate the secondary protection component. Complete EMP protection systems can be provided either in the form of individually packaged components, or as all-in-one EMP modules.

MPE are also able to offer a complete system design, installation, and testing service.

Please refer to our catalogue on EMP Products and Services for more details.

## Tempest Applications

Where the integrity of secure information is concerned, maximum filtering performance across the widest range of frequencies is vital. This catalogue includes several ranges of filters which offer a very wide stopband performance of 100dB from 10kHz to well above 10GHz.

MPE have produced many special designs for TEMPEST applications, and as members of the Industrial TEMPEST Scheme run by CESG, MPE are able to keep up to date with the latest TEMPEST requirements.

## Electrical Design Features

### Multiple Line Filters with Current Compensating Inductors

All multiple line filters in this catalogue use a modern filter design employing toroidal current compensating inductors or "coupled chokes". Multiple windings are used on the same inductor core to achieve flux cancellation and thus full insertion loss performance up to full rated current as the inductor does not saturate.

Empirical testing has proven that this advanced filter design gives identical insertion loss performance under no-load, half-load, and full-load current conditions over the full frequency range.

The use of current compensating inductors permits the use of high permeability cores to give large inductance values.

This results in a much higher performance filter with lower leakage current and lower heat dissipation than for the older type of single line filter design still used by many manufacturers of power line filters. (Single line filters have been widely used in the past for many applications but they have a number of significant disadvantages including the loss in performance as load current increases.)

To ensure maximum benefit is obtained from MPE's highly efficient coupled choke filter designs, the load current must always return through the filter to achieve current cancellation i.e. these filters should not be used on single lines, and on the load side of the filter the neutral must not be earthed or joined to neutrals from other sources.

As current returns through the filter in most power line applications, this type of filter design should always be the first choice for power lines as it offers the best size and performance combination.

These filter designs are equally suitable for three phase supplies with no neutral. The filter neutral line should be left unconnected, and must not be grounded.

## Single Line Filters

There are some special applications where single line filters may still be required such as where there may be a common return or an earth return path. To satisfy such requirements, this catalogue also includes single line filter designs up to 200A.

On any single line filter, the inductor core will progressively saturate as the load current is increased, and the filter insertion loss at low frequencies will consequently reduce.

On our single line filters, the insertion loss figures quoted are the full load performance figures. As the load current is reduced, a higher performance will thus be provided by the filter.

Single line filters are particularly suitable for control line applications. However, in control line applications, consideration should always be given to compatibility between the control circuits and the filter circuitry in terms of capacitance to earth, discharge resistors, d.c. resistance etc.

Our separate catalogue on control line filters offers complementary ranges of high performance control line filters covering lower current ratings down to 1A.

If you have any doubt about your application, we will be pleased to advise the most effective filter solution.

## Capacitors

The latest metallised plastic film dielectric capacitors are used in all of MPE's power line filters for maximum reliability and size efficiency. In a.c. filter designs, series metallised capacitors are used with very high overvoltage capability to give a high safety factor and excellent reliability.

High quality feedthrough capacitors are used in all filters to provide good transient handling capability and optimum high frequency performance.

## Discharge Resistors

For enhanced safety, all filters in this catalogue are fitted with internal discharge resistor networks. These are intended to discharge the capacitors to a safe voltage within one minute of removing power from the filter. As the resistance of the discharge network will always be less than 1 Megohm, the use of a 'Megger' type instrument to check installed filters could erroneously indicate a fault so should only be used with caution (and should not be used at all on transient suppressed filters).

## Transient Suppression

By virtue of their low inductance feedthrough construction, MPE's filter input capacitors are extremely effective in absorbing voltage transients even for rapid pulses with nanosecond rise times.

Where an extra stage of transient suppression is required, or when the energy or the voltage of incoming transients is likely to exceed the capability of the filter capacitors, filters can be supplied with varistor transient suppressors fitted to the filter input terminals to provide additional protection.

These filters are specially designed to permit easy renewal of transient suppressors, if necessary.

## Overload Withstand Capability

Unless otherwise stated, filters in this catalogue are designed to meet the following overload conditions:

### Current Overload:

10 times maximum rated current for 1 second.

1.5 times maximum rated current for 10 minutes.

It is not recommended that any filter is operated above its continuous rated current for any extended period because of the substantial heating effect of overload current.

### Voltage Overload:

1.1 times maximum rated voltage continuously.

1.5 times maximum rated voltage for 1 minute. (excluding transient suppressed types)

D.C. filters are proof voltage tested at twice rated voltage.

All a.c. filters in this catalogue are proof voltage tested between each live line and earth at 2250V d.c. and at 1150V d.c. between live and neutral lines.

A.C. filters are designed for use on mains supplies with no more than 5% total harmonic distortion.

These factory tests are carried out prior to fitting of any transient suppressors and should not be repeated.

Overvoltage testing (including "Megger" testing) should not be carried out on transient suppressed filters as the varistors could be damaged.

## Volt Drop

Volt drop figures, where quoted, relate to the resistive volt drop per line. It is measured using a d.c. current equivalent to the full load r.m.s. current. This is generally of more interest to the user than a.c. volt drop as it relates directly to power dissipation.

## Low Leakage Filters

To provide good low frequency performance, all conventional a.c. power line filters have large values of capacitance between live and earth lines. This gives rise to a mains frequency leakage current which can be up to several amps in very high performance filters (and may be even greater in certain single line designs).

MPE's proprietary low leakage filter designs have no direct capacitance from live to earth but rather have capacitance from live to neutral and from neutral to earth.

This means that the continuous earth leakage current depends only on the neutral to earth voltage, and may be as little as 15mA per N-E volt at 50Hz. In practice, the value achieved may be somewhat higher depending on the harmonic content of the neutral waveform.

Low leakage filters are intrinsically safer than conventional filters because of their lower earth leakage current, and because the leakage current is derived from a low source potential.

All of our ranges of low leakage filters incorporate our modern current compensated choke design, as previously described.

To ensure that low leakage filters operate correctly, they must be used on a supply with a neutral, and terminal polarity must be observed. The neutral should not be earthed on the load side of the filter. N.B. Conventional three phase filters will also provide a reasonably low earth leakage current under normal operating conditions due to cancelling of the earth leakage currents from the three phases. They will not, however, share the enhanced safety benefits inherent in our low leakage designs.

## "Two Phase" Filters

This range of filters has been specifically developed to provide optimum performance under the special conditions where two phases are taken from a three phase supply, instead of live and neutral. These filters are also ideal where a single phase supply is "floating" with neither line tied to neutral, such as in certain shipborne applications, or where isolating transformers are used.

## 400Hz Filters

In all 400Hz filters, leakage current is higher than for 50Hz filters because of the increased operating frequency. Where generators are used, it should be remembered that the generator must supply not only the load current but also the filter reactive (leakage) current. Consideration should be given to any harmonics on the 400Hz supply which may cause additional heating within filters.

In addition to using low loss capacitors to minimise heat dissipation, our ranges of 400Hz filters incorporate current compensating inductors as previously described. This gives the added benefit of reduced capacitance values and consequently lower leakage currents to achieve a given performance, compared to single line filter designs.

## Very High Current Filters

Our unique ranges of very high current filters up to 2400A offer the benefits of using both our low leakage filter design and current compensating inductors. For filters of such a high current rating, they offer exceptional performance, and have an extremely low heat dissipation. This provides very low running costs and high reliability.

The busbar connections may either be drilled or clamped, to ensure low resistance power connections are made. Because of the very high current ratings, it is important that all conductors pass through a common cable entry point to avoid eddy current heating effects.

In view of the specialist nature of these filters, customised terminal chambers can be supplied to interface to individual installations.

## Insertion Loss Performance

All filters detailed in this catalogue are high performance types designed to offer in excess of 100dB insertion loss to well beyond 10GHz in most cases.

Insertion loss performance quoted in this catalogue has been measured in the asymmetric mode in a 50 ohm system, generally in accordance with BS613 or BS6299 (CISPR17). Most filters will also give very substantial symmetric mode performance.

For single phase filters incorporating current compensating inductors, measurement is carried out on the two lines together (with current flowing through both for load measurements, as would be the case in practice).

For three phase filter measurements, all input lines are connected in parallel via capacitors. The output is connected to each line in turn in parallel with neutral. This gives comparable results to a single phase filter with the same component values.

Typical measured performance figures are quoted in this catalogue. For higher performance filters, the measured values quoted may be restricted by test equipment limitations. Special measurement techniques have shown the true performance to be between 120dB and 140dB in many cases.

All new filter designs are empirically checked for insertion loss up to 2GHz. Sample tests at 10GHz and 18GHz by independent test authorities have verified that full 100dB performance has been maintained even at these very high frequencies. Integrity of production filters is guaranteed by 100% testing for capacitance, power factor, inductance, voltage proof, insulation resistance, and volt drop.

## Insertion Loss in Different Impedance Systems

It must be recognised that insertion loss measurements made in a 50 ohm system (while giving good guidance and comparative performance figures) may differ from those achieved in practical situations.

This is because although mains supplies are assumed to be 50 ohm impedance as far as RFI is concerned, in practice the terminating impedances can be somewhat different from this.

In fact, the source impedance is likely to be much less than 50 ohms at the lower frequencies. BS6299 (CISPR 17) recognises this fact and suggests a second insertion loss test with 0.1 ohm source and 100 ohm load impedances. Although closer to many real system impedances, even this test cannot represent every practical situation so test results should only be used for comparative guidance.

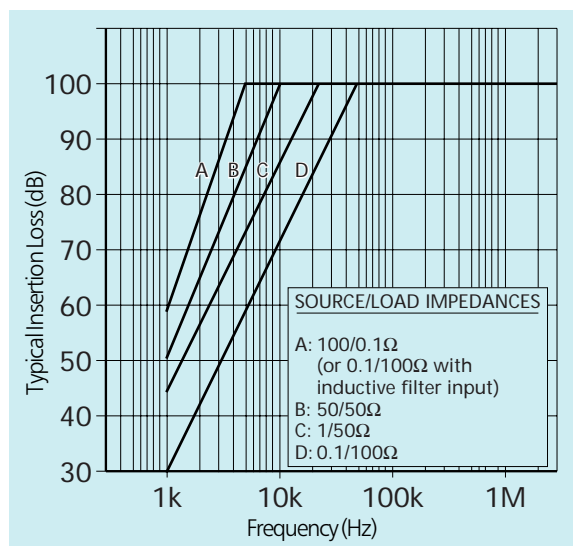

The above graph illustrates the effect of source and load impedance on insertion loss for a typical extended performance filter similar to the range shown on page 26.

Some filters in this catalogue (see page 26) have capacitive input and inductive output. The normal method of connection would be to use the capacitive input side towards the incoming mains to provide excellent high frequency transient response.

However, by connecting the filter with the inductive end facing the incoming mains, a better low frequency insertion loss may be provided in some practical situations such as where the source impedance is very low. This effect is also shown in the above graph.

More guidance on insertion loss in relation to system impedance can be given where actual impedances can be related to a particular filter.

Alternatively, custom filters can be designed to give optimum performance in a known system impedance.

## Mechanical Design Features

All ranges of filters within this catalogue are of rugged construction.

The tubular ranges of filters are housed in electro-tinned brass cases with epoxy resin encapsulation and end sealing and are finished in light grey military grade paint.

The rectangular ranges of filters are housed in electro-tinned steel cases and are finished in light grey military grade paint.

To minimise any radiation coupling, input and output terminals on all rectangular filters are physically isolated within RFI tight terminal compartments. The lids to these compartments are supplied with both RFI and resilient gaskets to provide excellent protection against radiated interference. Lids protecting the internal filter circuitry are secured with blind rivets and then completely solder sealed to provide maximum RF integrity.

The stud terminals on all filters are bright nickel plated and are supplied with nuts and washers.

## Installation

For optimum EMI performance, proper mounting of any filter is essential.

It is important to ensure as low as possible earth bond impedance to the unpainted base or mounting flange of the filter. This is necessary to obtain the best insertion loss from the filter, and also to carry away high pulse currents in transient suppressed filters.

We would normally recommend that filters are mounted on a steel surface which has been electroplated with tin or zinc. This should be unpainted and must be flat and smooth. Whilst other materials and finishes may be acceptable, the user should give consideration to the shielding and earth bonding properties and possible galvanic

corrosion effects of any materials used. In most cases, "conductive paint" finishes are unacceptable as they do not permit a sufficiently good earth bond to be made.

In any EMI filter, poor earth bonding will result in reduced insertion loss and could compromise safety. On rectangular filters, the user must ensure complete screening around all conduit entries and mounting screws. "Blackened" screws and washers should not be used.

Where penetration tubes are used to pass cables through the base of the filter and the mounting surface, they must also provide a complete RF seal. Commercial conduit fittings are of variable quality and are generally unsuitable to fulfil this requirement due to badly fitting threads. MPE's dedicated fixing kits have been introduced to overcome this problem and are detailed within this catalogue (see page 36).

Rectangular filters can be supplied with different cable entry hole positions to suit alternative mounting arrangements. These are illustrated on page 37.

Filter sizes and cable entries are designed to be a minimum for the filter current rating. The user is advised to verify that the standard filter terminal compartment and cable entry sizes are suitable for his application, especially where oversize cables may be used to minimise cable volt drop.

On rectangular filters, proper fitting of terminal compartment lids and gaskets is important, as shown in detail on page 37. Gaskets must be fitted in the specified positions. All lid screws must be fitted and tightened to the specified torque.

In circumstances where several rectangular filters are installed together, it is recommended that they are installed vertically with at least 25mm spacing to assist with convection cooling.

Tubular filters should be installed through a metal barrier which will provide screening between input and output terminals. Terminals should be enclosed by the user for safety reasons, and for additional screening, if needed.

All conductors should pass through single cable entries in accordance with the IEE regulations to avoid eddy current heating effects.

A complete installation service can be provided by qualified MPE installation personnel, if required. Details are available on request.

## Special Applications

### Use of Filters with RCCD's

All high performance power line filters incorporate comparatively large values of capacitance. This means that an RCCD can not be used ahead of the filter as the filter leakage current will cause the RCCD to trip.

This applies even to low leakage filters which may still trip RCCD's due to inrush current and variable leakage current resulting from harmonics on the neutral supply.

RCCD's will normally function correctly when connected on the load side of the filter.

## Other Special Applications

There are many applications where one type of filter design may be more effective than another or where special constraints may apply due to system requirements. Examples might be back-fed systems, unusual working voltage, current, or frequency, special system impedance etc.

In such cases, please consult us for advice on the selection of the most suitable filter design.

## Safety

All high performance filters contain capacitors which will store charge even after the power has been removed from the filter.

All of the filters listed in this catalogue are fitted with internal discharge resistor networks. These are intended to discharge the capacitors to a safe level within one minute of switching off the power.

N.B. To ensure capacitors are safely discharged, terminals must always be shorted to case and to each other (where applicable) prior to being touched.

For tubular and very high current filters, terminals must be enclosed to protect from the danger of shock. For transient suppressed versions, this is also important to protect the user in the event of a varistor rupturing following an extreme transient.

For all a.c. filters, it is essential for safety that the case of the filter is **SOLIDLY AND PERMANENTLY EARTHED** in accordance with the latest IEE Regulations. On no account should these filters be connected via a plug and socket.

Great care must be taken if any bench testing is to be carried out to ensure the case is solidly earthed. Where no company earth exists, such as on portable enclosures and vehicles, then earthing should be to a buried earth spike of an equivalent standard.

Good earthing is essential because in all conventional filters, in the event of the earth becoming disconnected during use, the filter case will rise in voltage to an unsafe level. Low leakage filters are safer in this respect.

For all filters, terminal polarity must be observed.

© MPE Limited - September 1994

# Single Line DC Filters (Tubular Cases)

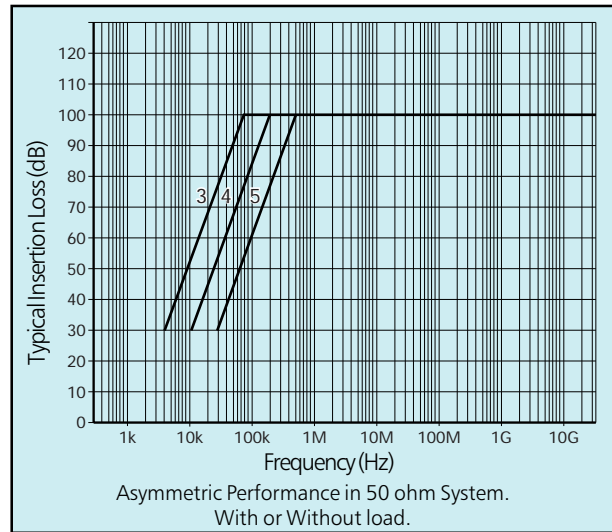

## Applications

These tubular d.c. power line filters are designed for bulkhead mounting to enable high packing densities to be achieved. They are suitable for all voltages up to 250V d.c. They are often used in military power supplies where their features of high performance, high current rating, and bulkhead mounting are major considerations. The electrical circuit is symmetrical so the filters may be mounted either way round but varistors, if fitted, would always be mounted on the identified input end.

## General Specification

Rated Voltage	: 250V d.c. (also suitable for up to 100V a.c. 50Hz)
Rated Current	: As tabulated opposite
Insertion Loss	: See graph and table Performance curve 3 meets 100dB at 80kHz Performance curve 4 meets 100dB at 200kHz Performance curve 5 meets 100dB at 500kHz
Maximum Temperature Rise on Full Load	: 25°C
Operating Temperature Range on Full Load	: -45°C to +50°C
Maximum Full Load Heat Dissipation	: As tabulated opposite
Maximum Volt Drop at Full Load Current	: As tabulated opposite
Discharge Time to Below 34V	: 30s maximum

## Transient Suppression

All types can be supplied with a varistor transient suppressor fitted between the input terminal and earth. Varistor rating : 325V d.c. 110 Joules (10/1000μs)  
To specify the transient suppressed version, suffix V is added to the filter part number (see ordering code).



# Single Line DC Filters (Rectangular Cases)

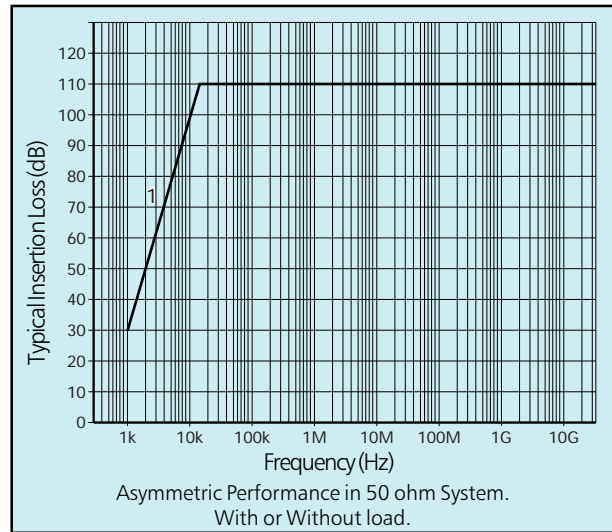

## Applications

These single line d.c. power line filters in a rectangular package are designed for mounting on a bulkhead. They are suitable for all voltages up to 250V d.c.

These filters may also be used on low voltage a.c. power lines up to 100V a.c. 50Hz.

## General Specification

Rated Voltage	: 250V d.c. (also suitable for up to 100V a.c. 50Hz)
Rated Current	: As tabulated opposite
Insertion Loss	: 100dB from 10kHz to 10GHz
Maximum Temperature Rise on Full Load	: 25°C
Operating Temperature Range on Full Load	: -45°C to +50°C
Maximum Full Load Heat Dissipation	: As tabulated opposite
Maximum Volt Drop at Full Load Current	: As tabulated opposite
Discharge Time to below 34V	: 60s maximum

## Dimensions and Mechanical Details

See table opposite for major dimensions. Detailed dimensions are given on page 39. Filters are housed in electroplated steel cases.

Dimensions are given in mm.

## Range Available

Current Rating (A)	MPE Part Number	Performance Curve	Volt Drop (V)	Heat Dissipation (W)	Major Dimensions (mm)			Case Size See Page 39	Approx Weight (kg)
					A	B	C		
5	DS26390	1	1	5	600	100	90	hh	12
10	DS26391	1	1	10	600	100	90	hh	12
30	DS23596	1	1	25	700	130	110	ii	20
60	DS23597	1	1	50	850	130	110	jj	25
100	DS23598	1	1	65	1000	160	130	kk	35
200	DS23599	1	1	130	1200	200	150	ll	60

## Transient Suppression

All types can be supplied with integral transient suppression fitted between the input terminal and earth.

Varistor rating : 330V d.c. 130 Joules (10/1000µs)

Other varistor ratings can also be supplied.

To specify the transient suppressed version, suffix V is added to the filter part number (see ordering code).

## Typical Installation Details

Installation instructions are given on page 37. The standard cable entry consists of an end conduit entry hole on the filter input (supply) side and a base conduit exit hole on the output (load) side.

Filters can be supplied with other cable entry positions if required. These are detailed on page 37 and are specified by adding the appropriate suffix to the filter part number.

To facilitate installation of these filters, separate fixing kits are available to suit bulkhead panel thicknesses up to 20mm. Full details are given on page 36.

## Ordering Code:



# Two Line DC Filters

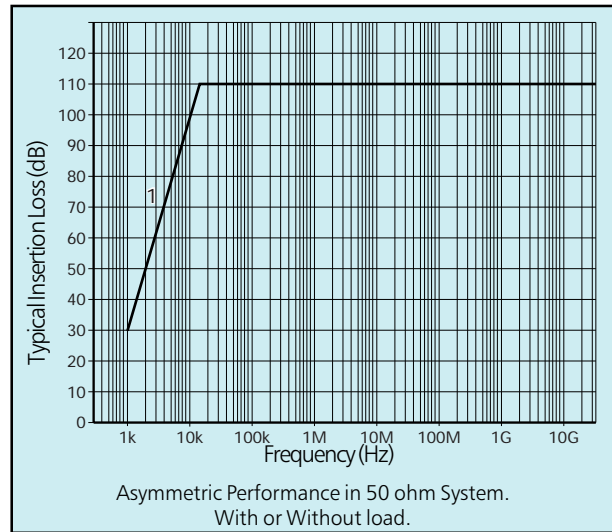

## Applications

These two line d.c. power line filters feature the full benefits of using current compensating inductors as described in the technical notes on page 5. They are housed in rectangular enclosures and are designed for mounting on a bulkhead. They are suitable for all voltages up to 250V d.c.

To achieve the full benefits of the high performance filter design, it is important that the load current returns through the filter.

## General Specification

Rated Voltage	: 250V d.c. (also suitable for up to 100V a.c. 50Hz)
Rated Current	: As tabulated opposite
Insertion Loss	: 100dB from 10kHz to 10GHz
Maximum Temperature Rise on Full Load	: 25°C
Operating Temperature Range on Full Load	: -45°C to +50°C
Maximum Full Load Heat Dissipation	: As tabulated opposite
Maximum Volt Drop per line at Full Load Current	: As tabulated opposite
Discharge Time to Below 34V	: 60s maximum

## Dimensions and Mechanical Details

See table opposite for major dimensions. Detailed dimensions are given on page 38. The filters are housed in electroplated steel cases.

Dimensions are given in mm.

## Range Available

Current Rating (A)	MPE Part Number	Performance Curve	Volt Drop (mV)	Heat Dissipation (W)	Major Dimensions (mm)			Case Size See Page 38	Approx Weight (kg)
					A	B	C		
5	DS23870	1	500	5	310	175	90	a	8
10	DS23871	1	500	10	310	175	90	a	8
30	DS23872	1	500	20	550	205	95	e	16
60	DS23873	1	500	45	550	205	105	f	20
100	DS23874	1	500	60	640	205	120	i	25
200	DS23875	1	500	110	660	475	135	u	60

## Transient Suppression

All types can be supplied with integral transient suppression fitted between each input terminal and earth.

Varistor rating : 330V d.c. 130 Joules (10/1000µs).

Other varistor ratings can also be supplied.

To specify the transient suppressed version, suffix V is added to the filter part number (see ordering code).

## Typical Installation Details

Installation instructions are given on page 37. The standard cable entry consists of an end conduit entry hole on the filter input (supply) side and a base conduit exit hole on the output (load) side.

Filters can be supplied with other cable entry positions if required. These are detailed on page 37 and are specified by adding the appropriate suffix to the filter part number.

To facilitate installation of these filters, separate fixing kits are available to suit bulkhead panel thicknesses up to 20mm. Full details are given on page 36.

## Ordering Code:



# Single Line AC Filters (Tubular Cases)

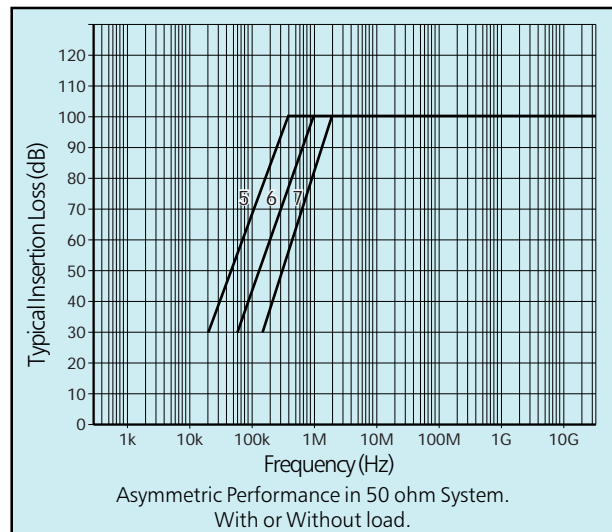

## Applications

These tubular a.c. power line filters are designed for mounting through a bulkhead. Because of the end mounting gland they are suitable for high packing density. They are suitable for all voltages up to 250V a.c. at 50/60Hz, and may also be used on d.c. supplies up to 600V d.c.

## General Specification

Rated Voltage	: 250V a.c. 50/60Hz (also suitable for up to 600V d.c.)
Rated Current	: As tabulated opposite
Insertion Loss	: See graph and table Performance curve 5 meets 100dB at 350kHz Performance curve 6 meets 100dB at 900kHz Performance curve 7 meets 100dB at 2MHz
Maximum Temperature Rise on Full Load	: 25°C
Operating Temperature Range on Full Load	: -45°C to +50°C
Maximum Full Load Heat Dissipation	: As tabulated opposite
Maximum Volt Drop at Full Load d.c. Current	: As tabulated opposite
Discharge Time to Below 34V	: 10s maximum

## Transient Suppression

All types can be supplied with varistor transient suppressors fitted between the input terminal and earth. Varistor rating : 275V a.c. 130 Joules (10/1000µs)  
To specify the transient suppressed version, suffix V is added to the filter part number (see ordering code).

## Range Available

Current Rating (A)	MPE Part Number	Performance Curve	Volt Drop (mV)	Heat Dissipation (W)	Major Dimensions (mm)			Approx Weight (kg)
					A	L	W	
6	DS26088	5	325	3	165	245	M6	1.2
10	DS26089	5	200	3	180	260	M6	1.2
30	DS26090	6	200	6	195	275	M6	1.5
60	DS26091	6	200	12	215	295	M6	1.5
100	DS26092	7	120	12	195	290	M8	1.8
200	DS26093	7	120	24	195	300	M10	1.8

## Dimensions and Mechanical Details

See table above for major dimensions. The filters are housed in electroplated brass tubes and are sealed with epoxy resin. The main body of the filter is finished in light grey paint.

Dimensions are given in mm.

Mounting and terminal nuts and washers are supplied.

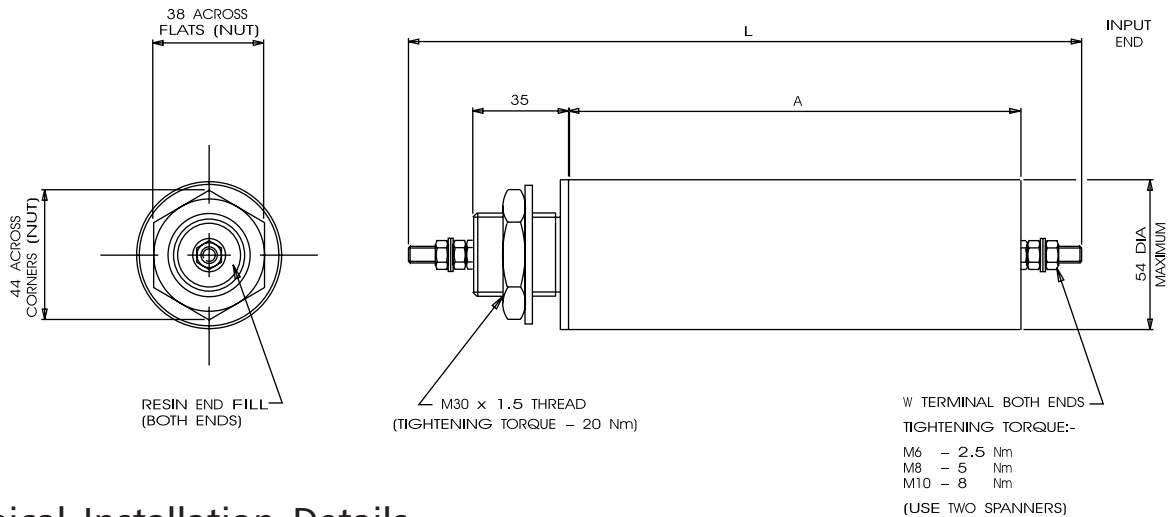

## Typical Installation Details

Any paint should be removed from the bulkhead around the fixing hole to ensure a good earth bond and RF seal.

RF washers, where fitted, should be fitted between the filter and bulkhead. A plain washer should be fitted between the mounting nut and bulkhead.

Terminals should be enclosed by the user after fitting the filter to prevent any danger of electric shock, and also to provide screening of incoming and outgoing lines.

## Ordering Code:

Filter Part Number \_\_\_\_\_ DS XXXXX / X  
 Add suffix V for transient suppressed filter \_\_\_\_\_

e.g. DS 26088V

# Single Line AC Filters (Rectangular Cases)

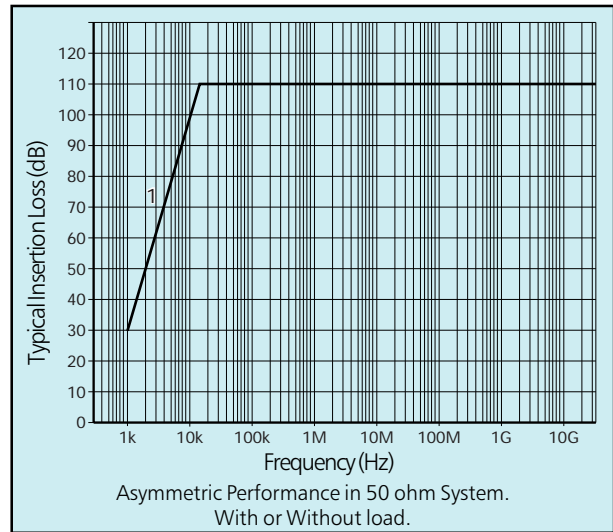

## Applications

These single line a.c. power line filters in a rectangular package are designed for mounting on a bulkhead. They are suitable for all voltages up to 250V a.c. 50/60Hz.

They are particularly suited to high current power and control line applications where the return current has to return via a different route.

## General Specification

Rated Voltage	: 250V a.c. 50/60Hz (also suitable for up to 600V d.c.)
Rated Current	: As tabulated opposite
Insertion Loss	: 100dB from 14kHz to 10GHz
Maximum Temperature Rise on Full Load	: 25°C
Operating Temperature Range on Full Load	: -45°C to +50°C
Maximum Full Load Heat Dissipation	: As tabulated opposite
Maximum Volt Drop at Full Load d.c. Current	: As tabulated opposite
Discharge Time to Below 34V	: 60s maximum

## Dimensions and Mechanical Details

See table opposite for major dimensions. Detailed dimensions are given on page 39. The filters are housed in electroplated steel cases.

Dimensions are given in mm.

## Range Available

Current Rating (A)	MPE Part Number	Performance Curve	Volt Drop (V)	Heat Dissipation (W)	Major Dimensions (mm)			Case Size See Page 39	Approx Weight (kg)
					A	B	C		
5	DS26394	1	1	8	600	100	90	hh	12
10	DS26395	1	1	15	600	100	90	hh	12
30	DS26396	1	1	35	700	130	110	ii	20
60	DS26397	1	1	60	850	130	110	jj	25
100	DS26398	1	1	75	1000	160	130	kk	35
200	DS26399	1	1	150	1200	200	150	ll	60

## Transient Suppression

All types can be supplied with integral transient suppression fitted between the input terminal and earth.

Varistor rating : 275V a.c. 140 Joules (10/1000µs)

Other varistor ratings can also be supplied.

To specify the transient suppressed version, suffix V is added to the filter part number (see ordering code).

## Typical Installation Details

Installation instructions are given on page 37. The standard cable entry consists of an end conduit entry hole on the filter input (supply) side and a base conduit exit hole on the output (load) side.

Filters can be supplied with other cable entry positions if required. These are detailed on page 37 and are specified by adding the appropriate suffix to the filter part number.

To facilitate installation of these filters, separate fixing kits are available to suit bulkhead panel thicknesses up to 20mm. Full details are given on page 36.

## Ordering Code:

Filter Part Number \_\_\_\_\_ DS XXXXX / X / X e.g. DS26394CV

Suffix C for standard cable entry  
For other cable entries, see page 37 \_\_\_\_\_

Add suffix V for transient suppressed filter \_\_\_\_\_

# Standard Range

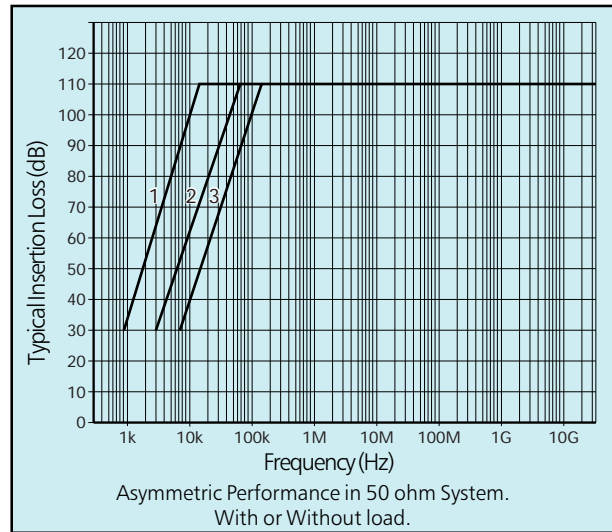
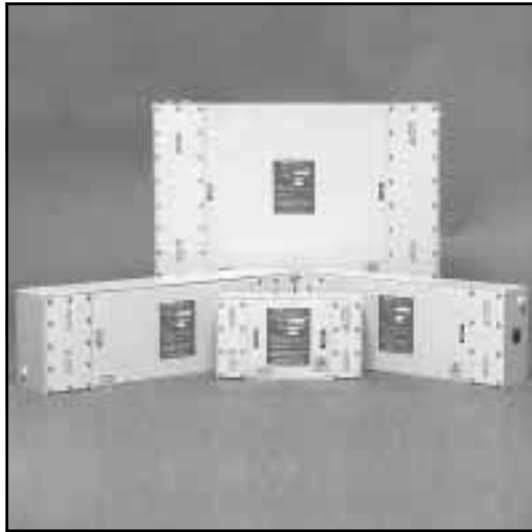

## Applications

From screened rooms to industrial power equipment, uncontrolled radio interference presents a common hazard. This range of filters is designed specifically for use on single and three phase mains, and has all the advantages of using current compensating inductors.

Three phase filters are also suitable for three phase supplies without neutral. In such installations, the neutral terminal should be left unconnected.

## General Specification

Rated Voltage	: Single Phase Filters	: 250V a.c. 50/60Hz (also suitable for 2 line d.c. supplies up to 600V d.c. provided that load current returns through the filter)
	: Three Phase Filters	: 250/440V a.c. 50/60Hz
Rated Current		: As tabulated opposite
Insertion Loss		: See graph and table Performance curve 1 meets 100dB at 10kHz Performance curve 2 meets 100dB at 50kHz Performance curve 3 meets 100dB at 100kHz
Maximum Temperature Rise on Full Load		: 25°C
Operating Temperature Range on Full Load		: -45°C to +50°C
Maximum Full Load Heat Dissipation		: As tabulated opposite
Maximum Volt Drop per line at Full Load d.c. Current		: As tabulated opposite
Discharge time to below 34V		: 30s maximum

## Dimensions and Mechanical Details

See table opposite for major dimensions. Detailed dimensions are given on page 38. The filters are housed in electroplated steel cases.

Dimensions are given in mm.

## Range Available

Current Rating (A)	MPE Part Number	Performance Curve	Volt Drop (mV)	Heat Dissipation (W)	Major Dimensions (mm)			Case Size See Page 38	Approx Weight (kg)
					A	B	C		
Single Phase ( +N)									
5	DS23547	1	500	7	310	175	90	a	8
10	DS23330	1	500	11	310	175	90	a	8
15	DS23752	1	500	14	310	175	90	a	8
30	DS23332	1	500	22	550	205	95	e	16
60	DS23334	1	500	50	550	205	105	f	20
100	DS23336	2	500	60	640	205	120	i	22
200	DS23708	3	500	120	660	475	135	u	60
400	DS26050	3	500	150	1250	475	150	mm	110
Three Phase ( +N)									
5	DS23619	2	500	11	310	350	90	b	16
10	DS23331	2	500	16	310	350	90	b	16
30	DS23333	1	500	45	550	410	95	g	22
60	DS23335	2	500	70	550	410	110	h	32
100	DS23337	2	500	70	660	410	135	j	45
200	DS23709	3	500	160	660	575	150	v	70
400	DS26051	3	500	170	1250	575	150	nn	120

## Transient Suppression

All types can be supplied with integral transient suppression fitted between each input terminal and earth.

Varistor rating : 275V a.c. 140 Joules (10/1000µs)  
Other varistor ratings can also be supplied.

To specify the transient suppressed version, suffix V is added to the filter part number (see ordering code).

## Typical Installation Details

Installation instructions are given on page 37. The standard cable entry consists of an end conduit entry hole on the filter input (supply) side and a base conduit exit hole on the output (load) side.

Filters can be supplied with other cable entry positions if required. These are detailed on page 37 and are specified by adding the appropriate suffix to the filter part number.

To facilitate installation of these filters, separate fixing kits are available to suit bulkhead panel thicknesses up to 20mm. Full details are given on page 36.

## Ordering Code:

Filter part Number \_\_\_\_\_ DS XXXXX / X / X e.g. DS23547CV

Suffix C for standard cable entry  
For other cable entries, see page 37 \_\_\_\_\_

Add suffix V for transient suppressed filter \_\_\_\_\_

# Extended Performance Range

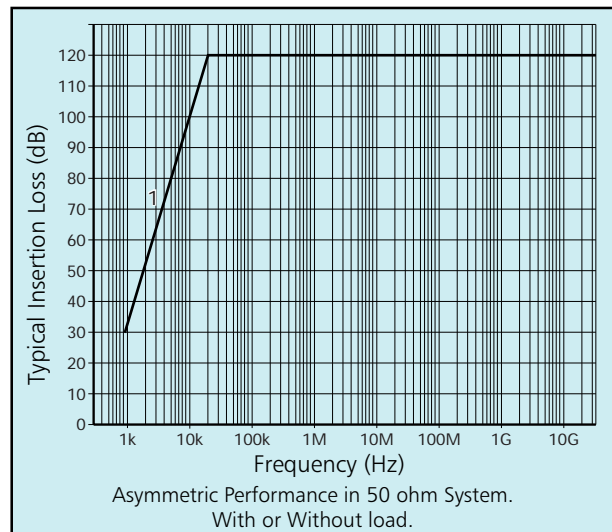
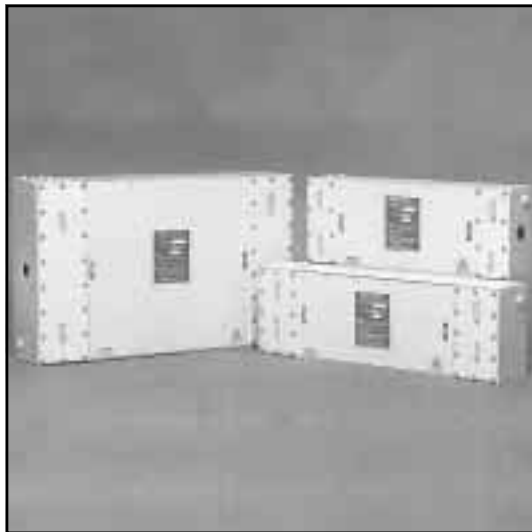

## Applications

This range of filters has been designed to meet the very highest insertion loss requirement of 100dB from 10kHz to 10GHz and features an extended low frequency performance to provide considerable filter attenuation at frequencies as low as 1kHz.

Available in current ratings from 6 amps to 400 amps in both single and three phase versions, these filters are ideally suited for TEMPEST, EMP, and similar applications where the very highest performance is required.

## General Specification

Rated Voltage	: Single Phase Filters	: 250V a.c. 50/60Hz (also suitable for 2 line d.c. supplies up to 600V d.c. provided that load current returns through the filter)
	: Three Phase Filters	: 250/440V a.c. 50/60Hz
Rated Current		: As tabulated opposite
Insertion Loss		: 100dB from 10kHz to 10GHz
Maximum Temperature Rise on Full Load		: 25°C
Operating Temperature Range on Full Load		: -45°C to +50°C
Maximum Full Load Heat Dissipation		: As tabulated opposite
Maximum Volt Drop per line at Full Load d.c. Current		: As tabulated opposite
Discharge time to below 34V		: 30s maximum

## Dimensions and Mechanical Details

See table opposite for major dimensions. Detailed dimensions are given on page 38. The filters are housed in electroplated steel cases.

Dimensions are given in mm.

## Range Available

Current Rating (A)	MPE Part Number	Performance Curve	Volt Drop (mV)	Heat Dissipation (W)	Major Dimensions (mm)			Case Size See Page 38	Approx Weight (kg)
					A	B	C		
Single Phase ( +N)									
6	DS25940	1	500	8	310	175	90	a	8
10	DS25941	1	500	11	310	175	90	a	8
16	DS25942	1	500	15	550	205	95	e	16
32	DS25943	1	500	25	550	205	95	e	18
63	DS25944	1	500	52	640	205	120	i	22
100	DS25945	1	500	60	660	475	135	u	60
200	DS26060	1	500	120	750	500	160	pp	75
400	DS26062	1	500	160	1050	525	185	qq	110
Three Phase ( +N)									
6	DS25946	1	500	12	310	350	90	b	16
10	DS25947	1	500	16	310	350	90	b	16
16	DS25948	1	500	25	550	410	95	g	22
32	DS25949	1	500	48	550	410	95	g	24
63	DS25950	1	500	70	660	410	135	j	45
100	DS25951	1	500	70	660	575	150	v	70
200	DS26061	1	500	120	750	700	170	rr	95
400	DS26063	1	500	240	1700	700	170	ss	200

## Transient Suppression

All types can be supplied with integral transient suppression fitted between each input terminal and earth.

Varistor rating : 275V a.c. 140 Joules (10/1000µs)

Other varistor ratings can also be supplied.

To specify the transient suppressed version, suffix V is added to the filter part number (see ordering code).

## Typical Installation Details

Installation instructions are given on page 37. The standard cable entry consists of an end conduit entry hole on the filter input (supply) side and a base conduit exit hole on the output (load) side.

Filters can be supplied with other cable entry positions if required. These are detailed on page 37 and are specified by adding the appropriate suffix to the filter part number.

To facilitate installation of these filters, separate fixing kits are available to suit bulkhead panel thicknesses up to 20mm. Full details are given on page 36.

## Ordering Code:

Filter Part Number \_\_\_\_\_ DS XXXXX / X / X

Suffix C for standard cable entry  
For other cable entries, see page 37 \_\_\_\_\_

Add suffix V for transient suppressed filter \_\_\_\_\_

e.g. DS25940CV

# Low Leakage Range

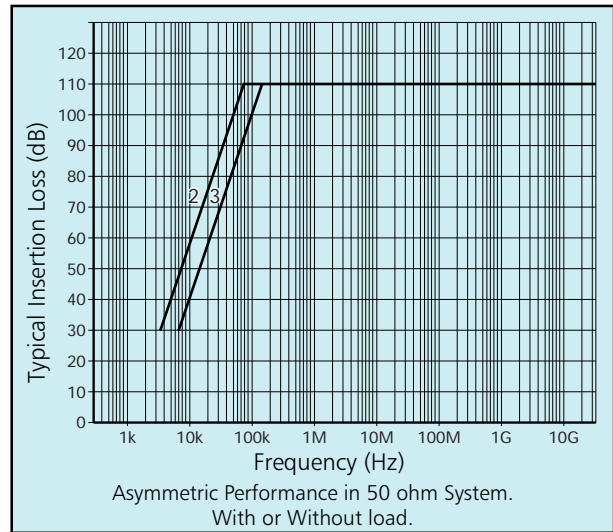
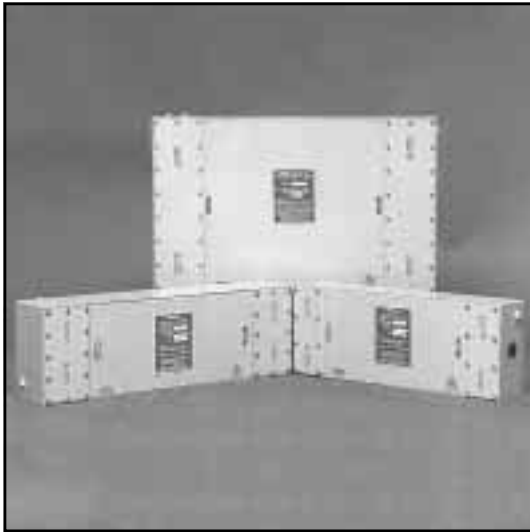

## Applications

This range of single and three phase filters features a low leakage construction offering increased levels of safety. Applications include secure communications systems, computer installations, and portable screened enclosures. These filters are designed for use on mains supplies with a dedicated neutral. The benefits to be obtained by using MPE's proprietary low leakage filter designs together with conditions of operation are described in detail in the technical notes on page 7 of this catalogue.

## General Specification

Rated Voltage	: Single Phase Filters	: 250V a.c. 50/60Hz (also suitable for 2 line d.c. supplies up to 600V d.c. provided that load current returns through the filter)
	: Three Phase Filters	: 250/440V a.c. 50/60Hz
Rated Current		: As tabulated opposite
Insertion Loss		: See graph and table Performance curve 2 meets 100dB at 50kHz Performance curve 3 meets 100dB at 100kHz
Maximum Temperature Rise on Full Load		: 25°C
Operating Temperature Range on Full Load		: -45°C to +50°C
Maximum Full Load Heat Dissipation		: As tabulated opposite
Maximum Volt Drop per line at Full Load d.c. Current		: 500mV
Discharge time to below 34V		: 30s maximum
Maximum Continuous Earth Leakage Current (per Neutral-Earth Volt at 50Hz)		: As tabulated opposite

## Dimensions and Mechanical Details

See table opposite for major dimensions. Detailed dimensions are given on page 38. The filters are housed in electroplated steel cases. Dimensions are given in mm.

## Range Available

Current Rating (A)	MPE Part Number	Performance Curve	Leakage Current (mA)	Heat Dissipation (W)	Major Dimensions (mm)			Case Size See Page 38	Approx Weight (kg)
					A	B	C		
Single Phase ( +N)									
5	DS23550	2	15	7	425	175	90	c	12
10	DS23551	2	15	11	425	175	90	c	12
15	DS26231	2	15	14	425	175	90	c	12
30	DS23552	2	25	21	550	205	95	e	16
60	DS23553	3	25	50	725	205	105	l	23
100	DS23554	3	30	60	760	205	120	n	28
200	DS25915	3	50	120	820	475	150	x	80
400	DS25917	3	100	150	1250	475	150	mm	110
Three Phase ( +N)									
5	DS23620	3	30	10	425	350	90	d	18
10	DS23555	3	30	15	425	350	90	d	18
30	DS23556	3	45	42	590	410	95	w	24
60	DS23557	3	55	68	725	410	110	m	42
100	DS23558	3	95	70	780	410	135	p	55
200	DS25916	3	150	160	820	575	150	y	85
400	DS25918	3	150	170	1250	575	150	nn	120

## Transient Suppression

All types can be supplied with integral transient suppression fitted between each input terminal and earth.

Varistor rating : 275V a.c. 140 Joules (10/1000µs)  
Other varistor ratings can also be supplied.

To specify the transient suppressed version, suffix V is added to the filter part number (see ordering code).

## Typical Installation Details

Installation instructions are given on page 37. The standard cable entry consists of an end conduit entry hole on the filter input (supply) side and a base conduit exit hole on the output (load) side.

Filters can be supplied with other cable entry positions if required. These are detailed on page 37 and are specified by adding the appropriate suffix to the filter part number.

To facilitate installation of these filters, separate fixing kits are available to suit bulkhead panel thicknesses up to 20mm. Full details are given on page 36.

## Ordering Code:

Filter Part Number \_\_\_\_\_ DS XXXXX / X / X

Suffix C for standard cable entry  
For other cable entries, see page 37 \_\_\_\_\_

Add suffix V for transient suppressed filter \_\_\_\_\_

e.g. DS23550CV

# Low Leakage Extended Performance Range

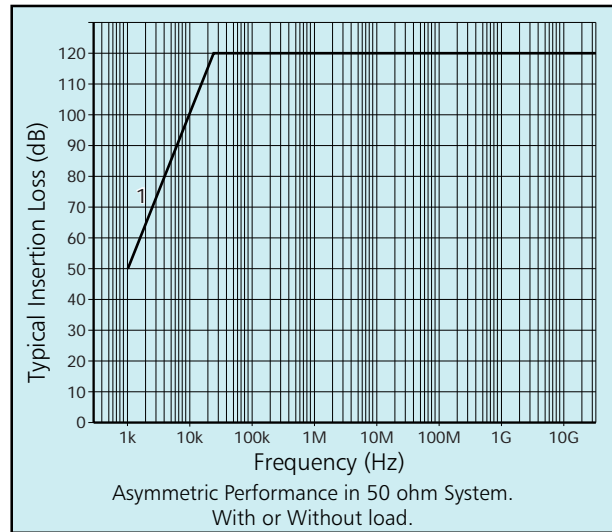

## Applications

Featuring full 100dB performance down to 10kHz, these proprietary single and three phase low leakage filters were originally developed to meet stringent requirements within modern military communications systems. However, with the increasing importance of high performance at low frequency and greater emphasis on increased safety, their applicability is now widespread.

For full details of the benefits of low leakage filters and their conditions of operation, please refer to the technical notes on page 7 of this catalogue.

Capacitive input and inductive output are standard features of this range. It is worth noting that, in certain circumstances, even greater low frequency performance can be achieved by using the filter in reverse. Terminal polarity must be maintained. (Please refer to notes on page 8 for more details.)

## General Specification

Rated Voltage	: Single Phase Filters	: 250V a.c. 50/60Hz (also suitable for 2 line d.c. supplies up to 600V d.c. provided that load current returns through the filter)
	: Three Phase Filters	: 250/440V a.c. 50/60Hz
Rated Current		: As tabulated opposite
Insertion Loss		: 100dB from 10kHz to 10GHz
Maximum Temperature Rise on Full Load		: 25°C
Operating Temperature Range on Full Load		: -45°C to +50°C
Maximum Full Load Heat Dissipation		: As tabulated opposite
Maximum Volt Drop per line at Full Load d.c. Current		: 1.2V
Discharge time to below 34V		: 60s maximum
Maximum Continuous Earth Leakage Current (per Neutral-Earth Volt at 50Hz)		: As tabulated opposite

## Dimensions and Mechanical Details

See table opposite for major dimensions. Detailed dimensions are given on page 38. The filters are housed in electroplated steel cases.

Dimensions are given in mm.

## Range Available

Current Rating (A)	MPE Part Number	Performance Curve	Leakage Current (mA)	Heat Dissipation (W)	Major Dimensions (mm)			Case Size See Page 38	Approx Weight (kg)
					A	B	C		
Single Phase ( +N)									
5	DS23548	1	20	15	725	175	90	k	15
10	DS23549	1	20	27	725	175	90	k	15
15	DS26232	1	20	36	725	175	90	k	15
30	DS23403	1	60	55	820	350	120	q	42
60	DS23425	1	60	115	970	350	120	r	62
100	DS23466	1	80	200	1206	350	150	s	100
200	DS23467	1	120	400	1206	573	162	t	150
400	DS26056	1	150	400	1750	650	180	z	240
Three Phase ( +N)									
5	DS23852	1	50	16	725	350	95	aa	30
10	DS23853	1	50	40	725	350	95	aa	30
30	DS23854	1	120	120	820	700	120	cc	85
60	DS23855	1	200	200	970	700	150	dd	130
100	DS23856	1	240	270	1206	700	162	ee	170
200	DS23857	1	280	500	1206	930	170	ff	230
400	DS23858	1	300	500	1750	1000	180	gg	320

## Transient Suppression

All types can be supplied with integral transient suppression fitted between each input terminal and earth.

Varistor rating : 275V a.c. 140 Joules (10/1000µs)  
Other varistor ratings can also be supplied.

To specify the transient suppressed version, suffix V is added to the filter part number (see ordering code).

## Typical Installation Details

Installation instructions are given on page 37. The standard cable entry consists of an end conduit entry hole on the filter input (supply) side and a base conduit exit hole on the output (load) side.

Filters can be supplied with other cable entry positions if required. These are detailed on page 37 and are specified by adding the appropriate suffix to the filter part number.

To facilitate installation of these filters, separate fixing kits are available to suit bulkhead panel thicknesses up to 20mm. Full details are given on page 36.

## Ordering Code:

Filter Part Number \_\_\_\_\_ DS XXXXX / X / X      e.g. DS23548CV

Suffix C for standard cable entry  
For other cable entries, see page 37 \_\_\_\_\_

Add suffix V for transient suppressed filters \_\_\_\_\_

## "2 Phase" Range

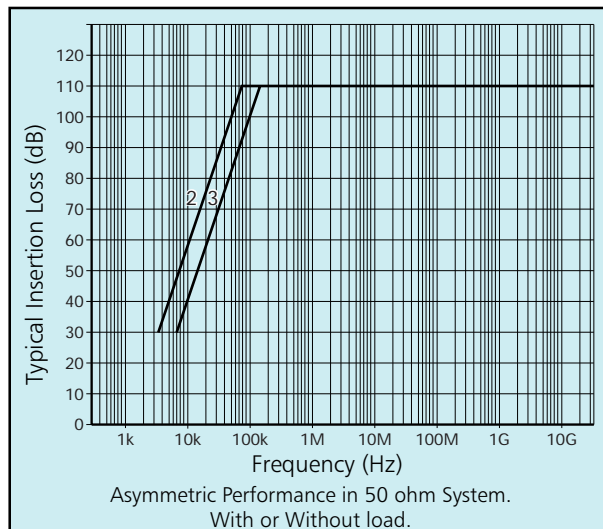

### Applications

This unique range of power line filters was designed and developed by MPE to provide optimum high performance filtering on special 2 line mains supplies where neither line is tied to neutral. Examples might be: marine generator supplies, two phases taken from a three phase supply, transformer isolated supplies, and certain European grid systems.

Current ratings from 5 amps to 400 amps per phase are available. All types can be supplied fitted with varistor transient suppressors if required.

### General Specification

Rated Voltage	: 250V a.c. 50/60Hz phase to earth : 440V a.c. 50/60Hz phase to phase (also suitable for 2 line d.c. supplies up to 600V d.c. provided that load current returns through the filter)
Rated Current	: As tabulated opposite
Insertion Loss	: See graph and table Performance curve 2 meets 100dB at 50kHz Performance curve 3 meets 100dB at 100kHz
Maximum Temperature Rise on Full Load	: 25°C
Operating Temperature Range on Full Load	: -45°C to +50°C
Maximum Full Load Heat Dissipation	: As tabulated opposite
Maximum Volt Drop per line at Full Load d.c. Current	: As tabulated opposite
Discharge time to below 34V	: 30s maximum

### Dimensions and Mechanical Details

See table opposite for major dimensions. Detailed dimensions are given on page 38. The filters are housed in electroplated steel cases.

Dimensions are given in mm.

## Range Available

Current Rating (A)	MPE Part Number	Performance Curve	Volt Drop (mV)	Heat Dissipation (W)	Major Dimensions (mm)			Case Size See Page 38	Approx Weight (kg)
					A	B	C		
Two Phase									
5	DS26365	2	500	7	310	175	90	a	8
10	DS26366	2	500	11	310	175	90	a	8
15	DS26367	2	500	14	310	175	90	a	8
30	DS26368	2	500	22	550	205	95	e	16
60	DS26369	2	500	50	550	205	105	f	20
100	DS26370	3	500	60	640	205	120	i	22
200	DS26371	3	500	120	660	475	135	u	60
400	DS26372	3	500	150	1250	475	150	mm	110

## Transient Suppression

All types can be supplied with integral transient suppression fitted between each input terminal and earth.

Varistor rating : 275V a.c. 140 Joules (10/1000µs)  
Other varistor ratings can also be supplied.

To specify the transient suppressed version, suffix V is added to the filter part number (see ordering code).

## Typical Installation Details

Installation instructions are given on page 37. The standard cable entry consists of an end conduit entry hole on the filter input (supply) side and a base conduit exit hole on the output (load) side.

Filters can be supplied with other cable entry positions if required. These are detailed on page 37 and are specified by adding the appropriate suffix to the filter part number.

To facilitate installation of these filters, separate fixing kits are available to suit bulkhead panel thicknesses up to 20mm. Full details are given on page 36.

## Ordering Code:

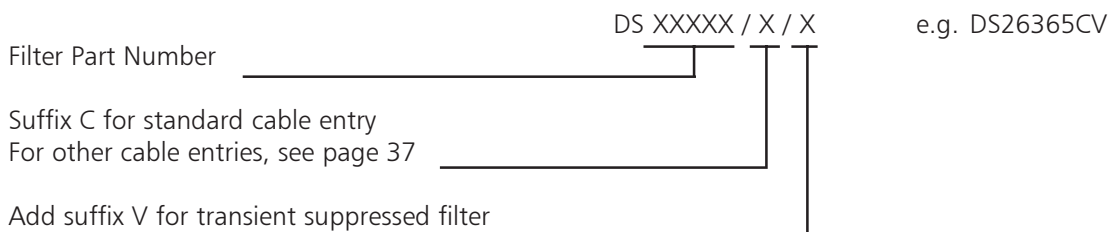

# 400Hz Range

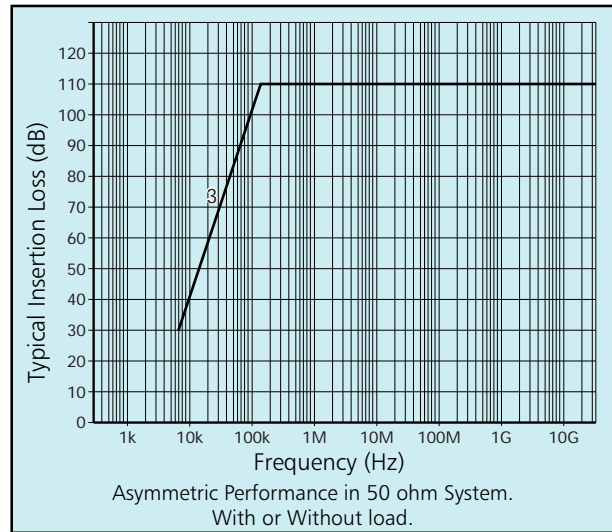
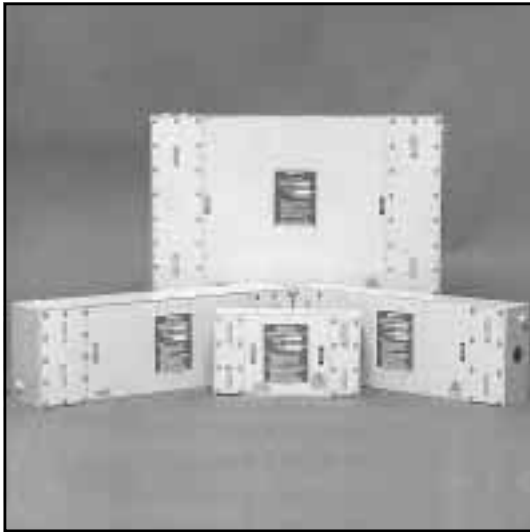

## Applications

This range of filters has been specially designed for use on 400Hz systems and utilises capacitors with low loss dielectric material to minimise heat dissipation. By using coupled choke designs, it has been possible to provide a good performance with comparatively low capacitance values and hence reactive current, but it must be remembered that at 400Hz, reactive current can be significant and this current has to be supplied by the generator as well as the load current.

Many 400Hz supplies have high levels of harmonic content. This can cause additional heating within filters, so if this is known to be the case, it is better to select a filter of higher current rating than would otherwise be required. In extreme cases of harmonic content, please contact our technical department for advice.

## General Specification

Rated Voltage	: Single Phase Filters	: 115V a.c. 400Hz
	: Three Phase Filters	: 115/200V a.c. 400Hz
Rated Current		: As tabulated opposite
Insertion Loss		: 100dB from 100kHz to 10GHz
Maximum Temperature Rise on Full Load		: 25°C
Operating Temperature Range on Full Load		: -45°C to +50°C
Maximum Full Load Heat Dissipation		: As tabulated opposite
Maximum Volt Drop per line at Full Load d.c. Current		: As tabulated opposite
Discharge time to below 34V		: 30s maximum

## Dimensions and Mechanical Details

See table opposite for major dimensions. Detailed dimensions are given on page 38. The filters are housed in electroplated steel cases.

Dimensions are given in mm.

## Range Available

Current Rating (A)	MPE Part Number	Performance Curve	Volt Drop (mV)	Heat Dissipation (W)	Major Dimensions (mm)			Case Size See Page 38	Approx Weight (kg)
					A	B	C		
Single Phase ( +N)									
5	DS25900	3	500	5	310	175	90	a	8
10	DS25901	3	500	11	310	175	90	a	8
30	DS25902	3	500	22	550	205	95	e	16
60	DS25903	3	500	50	550	205	105	f	20
100	DS25904	3	500	60	640	205	120	i	22
200	DS25905	3	500	120	660	475	135	u	60
Three Phase ( +N)									
5	DS23700	3	500	7	310	350	90	b	16
10	DS23605	3	500	15	310	350	90	b	16
30	DS23606	3	500	50	550	410	95	g	22
60	DS23607	3	500	70	550	410	110	h	32
100	DS23608	3	500	70	660	410	135	j	45
200	DS25907	3	500	160	660	575	150	v	70

## Transient Suppression

All types can be supplied with integral transient suppression fitted between each input terminal and earth.

Varistor rating : 150V a.c. 80 Joules (10/1000µs)

Other varistor ratings can also be supplied.

To specify the transient suppressed version, suffix V is added to the filter part number (see ordering code).

## Typical Installation Details

Installation instructions are given on page 37. The standard cable entry consists of an end conduit entry hole on the filter input (supply) side and a base conduit exit hole on the output (load) side.

Filters can be supplied with other cable entry positions if required. These are detailed on page 37 and are specified by adding the appropriate suffix to the filter part number.

To facilitate installation of these filters, separate fixing kits are available to suit bulkhead panel thicknesses up to 20mm. Full details are given on page 36.

## Ordering Code:

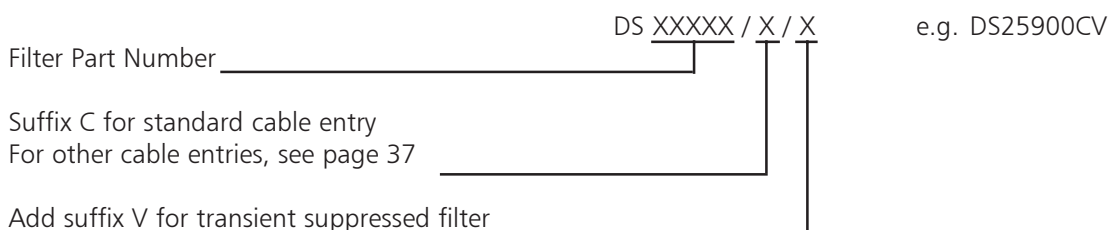

# Very High Current Range

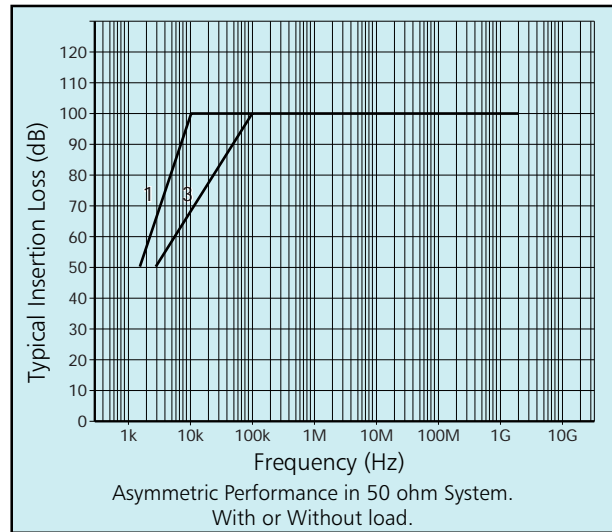
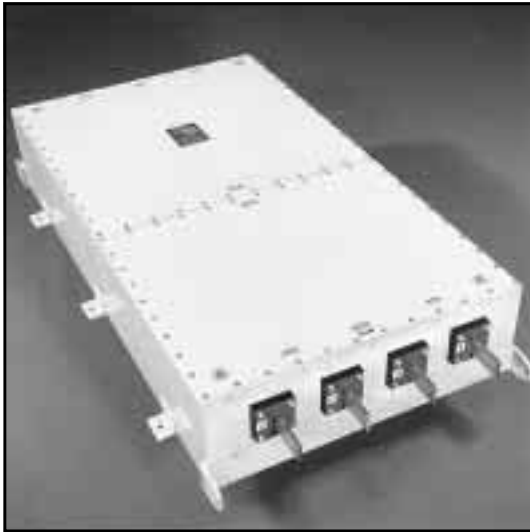

## Applications

This new range of filters has been developed for use on very high current three phase and neutral mains supplies. All filters employ MPE's proprietary low leakage filter design incorporating current compensating inductors to provide very low heat dissipation and hence running costs.

Two performance categories are offered both providing full insertion loss with or without load.

These filters are ideal for use in EMP protection systems and in TEMPEST applications.

The higher performance versions meet the filter attenuation requirements of MIL-STD 188-125 for use in high specification EMP protection systems.

Customised terminal chambers can be supplied to interface to individual installations.

All types are available with transient suppressors fitted to the input terminal busbars.

## General Specification

Rated Voltage	: 250/440V a.c. 50/60Hz
Rated Current	: As tabulated opposite
Insertion Loss	: Standard performance: 100dB 100kHz - 1GHz : Extended performance: 100dB 10kHz - 1GHz (See curves 3 and 1 respectively)
Maximum Temperature Rise on Full Load	: 16°C
Operating Temperature Range on Full Load	: -25°C to +50°C
Maximum Full Load Heat Dissipation	: As tabulated opposite
Maximum Volt Drop per line at Full Load d.c. Current	: As tabulated opposite
Maximum d.c. Resistance per line	: As tabulated opposite
Discharge Time to Below 34V	: 30s maximum
Maximum Continuous Earth Leakage Current (per Neutral-Earth Volt at 50Hz)	: 250mA
Maximum Overload Current Rating	: 1.25 times rated current for 15 minutes
Maximum Short Circuit Fault Current Rating	: 20,000A for 1 second

## Dimensions and Mechanical Details

See table opposite for major dimensions. Detailed dimensions are given on page 34.

## Range Available

Current Rating (A)	MPE Part Number	DC Resistance (mΩ)	Volt Drop (mV)	Heat Dissipation (W)	Major Dimensions (mm)			Case Style See Page 34	Approx Weight (kg)
					A	B	C		
Three Phase (+N) Standard Performance									
800	DS23973	0.13	100	250	1554	864	285	A	250
800	DS23521	0.13	100	250	1554	864	285	C	250
1200	DS26310	0.07	76	350	1600	1000	300	A	300
1200	DS26311	0.07	76	350	1600	1000	300	C	300
1600	DS26320	0.04	65	400	1800	1000	350	A	350
2400	DS26330	0.03	60	500	2600	1200	450	A	450
Three Phase (+N) Extended Performance									
800	DS26307	0.2	150	375	2400	864	285	A	350
800	DS26308	0.2	150	375	2400	864	285	C	350
1200	DS26314	0.1	115	550	2500	1000	300	A	450
1200	DS26315	0.1	115	550	2500	1000	300	C	450
1600	DS26324	0.06	100	600	2900	1000	350	A	550
2400	DS26334	0.04	90	750	4100	1200	450	A	650

**Note:** Extended performance filters are supplied as two interlocking parts for ease of handling and installation.

**Note:** "C" case styles are not offered for 1600A and 2400A filters as it is more practical to use a filter with case style "A" and penetrate the shield via the terminal enclosure.

## Transient Suppression

All types can be supplied with integral transient suppression fitted between each input terminal and earth.

Varistor rating : 275V a.c. 360 Joules  
Other varistor ratings can also be supplied.

To specify the transient suppressed version, suffix V is added to the filter part number (see ordering code).

## Typical Installation Details

General installation guidance notes are given on page 8. After mounting, for safety and for shielding purposes the filter terminals must be enclosed by screened covers. Custom terminal chambers and mounting frames can be supplied if required.

These filters have integral blind inserts to facilitate mounting and screening of terminal enclosures. They must not be used to support the weight of either the filter or the terminal enclosure.

Because of the very high current rating of these filters, it is important that all conductors pass through a common cable entry point in the shield to avoid eddy current heating effects.

## Ordering Code:

Filter Part Number \_\_\_\_\_ DS XXXXX / X \_\_\_\_\_ e.g. DS23973V  
Add suffix V for transient suppressed filter \_\_\_\_\_

# Very High Current Range Dimensions

## Standard Performance Filters

### Case Style A

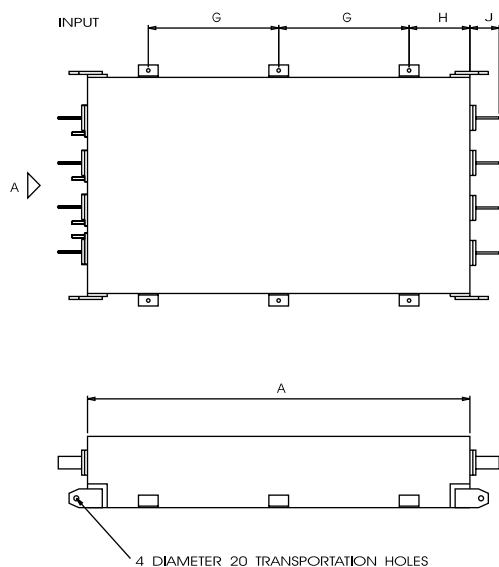

### Case Style C

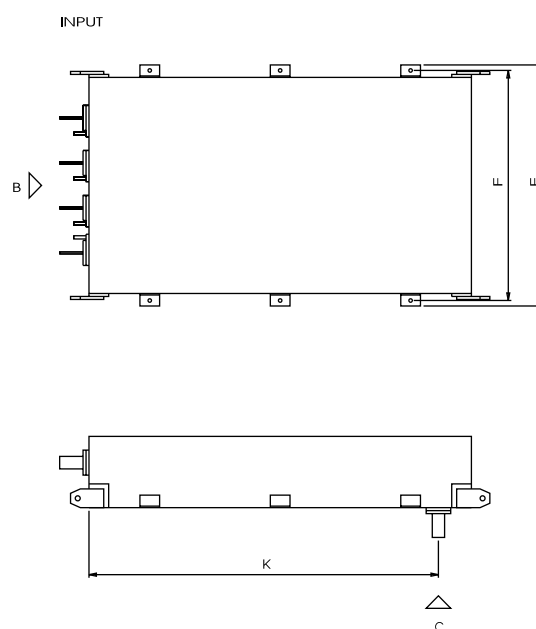

Transportation holes may be used for connection of a separate safety earth, if required.

## Extended Performance Filters

### Case Style A

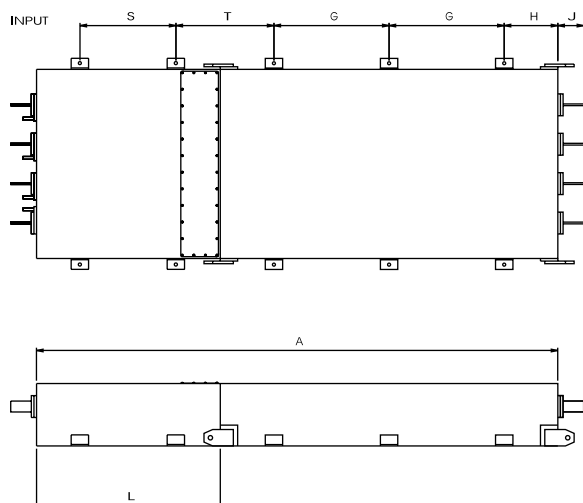

### Case Style C

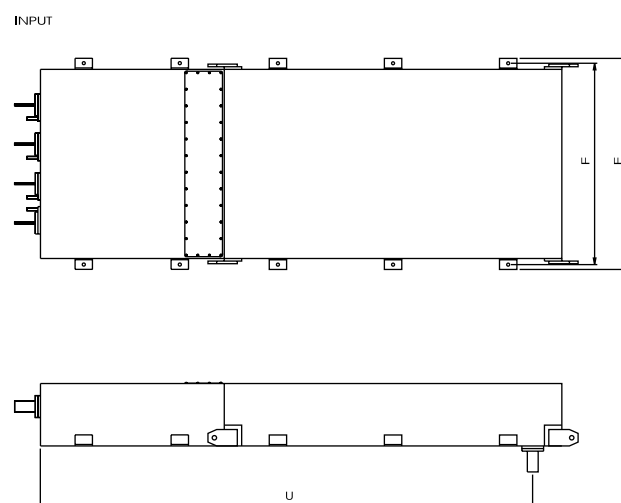

Note: Extended performance filters are supplied as two interlocking parts for ease of handling and installation. An interface gasket is supplied to join the two sections.

# Terminal Details

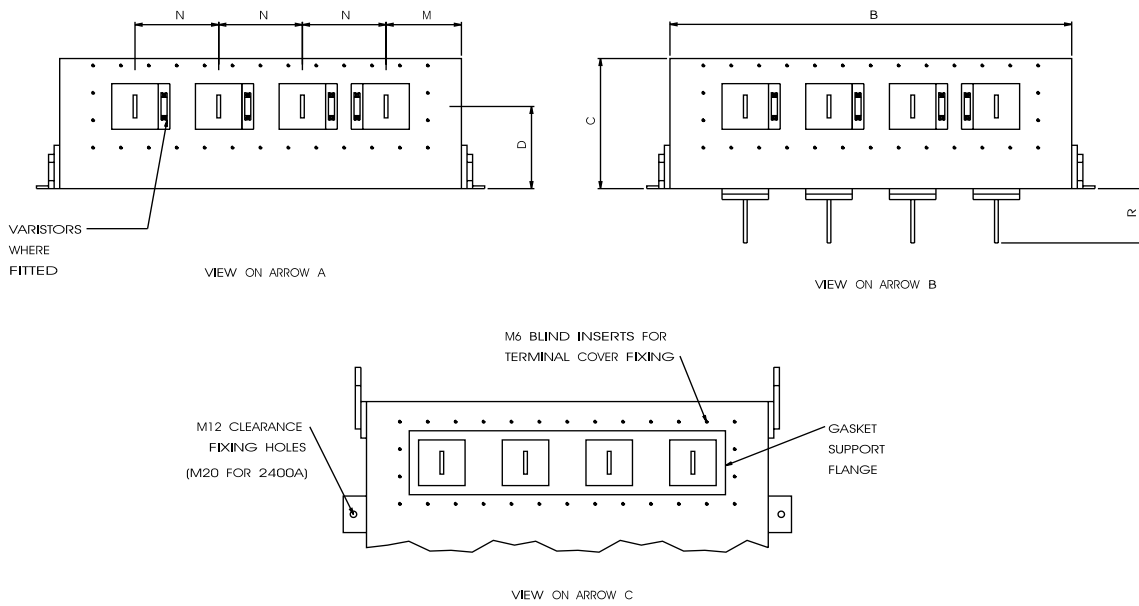

# Dimensions

Filter Current Rating (A)	Dimensions of Standard Performance Filters (mm)												
	A	B	C	D	E	F	G	H	J	K	M	N	R
800	1554	864	285	180	964	920	530	247	125	1420	162	180	125
1200	1600	1000	300	185	1100	1056	600	200	155	1450	125	250	155
1600	1800	1000	350	212	1100	1056	700	200	200	-	125	250	-
2400	2600	1200	450	255	1300	1256	1000	300	195	-	165	290	-

Filter Current Rating (A)	Dimensions of Extended Performance Filters (mm) (where different from above)				
	A	L	S	T	U
800	2400	846	442	450	2265
1200	2500	900	447	428	2350
1600	2900	1100	550	478	-
2400	4100	1500	900	600	-

Filter Current Rating (A)	Busbar Size (mm)
800	50 x 8
1200	80 x 10
1600	125 x 10
2400	Double bars each 120 x 10 with 10mm separation

# Fixing Kits

These high quality fixing kits have been designed to provide an RFI tight bulkhead penetration for cables to facilitate fixing of rectangular filters to bulkheads or walls of shielded enclosures. They make it easier to achieve a full RFI seal between filter case and bulkhead up to the highest frequencies, which is not usually achievable with standard electrical conduit fittings due to badly fitting threads.

Each bulkhead fixing kit comprises a penetration tube complete with nuts, heavy duty washers, gaskets, and end bushes for cable protection. The main components are made from electro-tinned steel. The fixing kit is ordered by specifying the MPE part number in the table below.

Fixing screw sets are also available separately. These are made from electro-tinned steel and comprise a set of four screws each with washers, nuts, and spring washers. They are selected by choosing the thread size appropriate to the filter fixing hole diameter.

## Bulkhead Fixing Kits



Cable Entry Hole Diameter (mm)	MPE Part Number Bulkhead Thickness up to 20mm
16	807146
20	807147
25	807148
32	807149
40	807150
50	807151
63	807152
75	807153

## Fixing Screw Sets



Fixing Hole Diameter (mm)	Screw Thread Size (mm)	MPE Part Number Bulkhead Thickness up to 20mm
4.5	M4	806950
5.5	M5	806951
7	M6	806952
9	M8	806953
11	M10	806954
13	M12	806955
17	M16	806956
21	M20	806957

# Installation Details

Typical installation details are shown below. See page 8 for further technical information relating to installation.

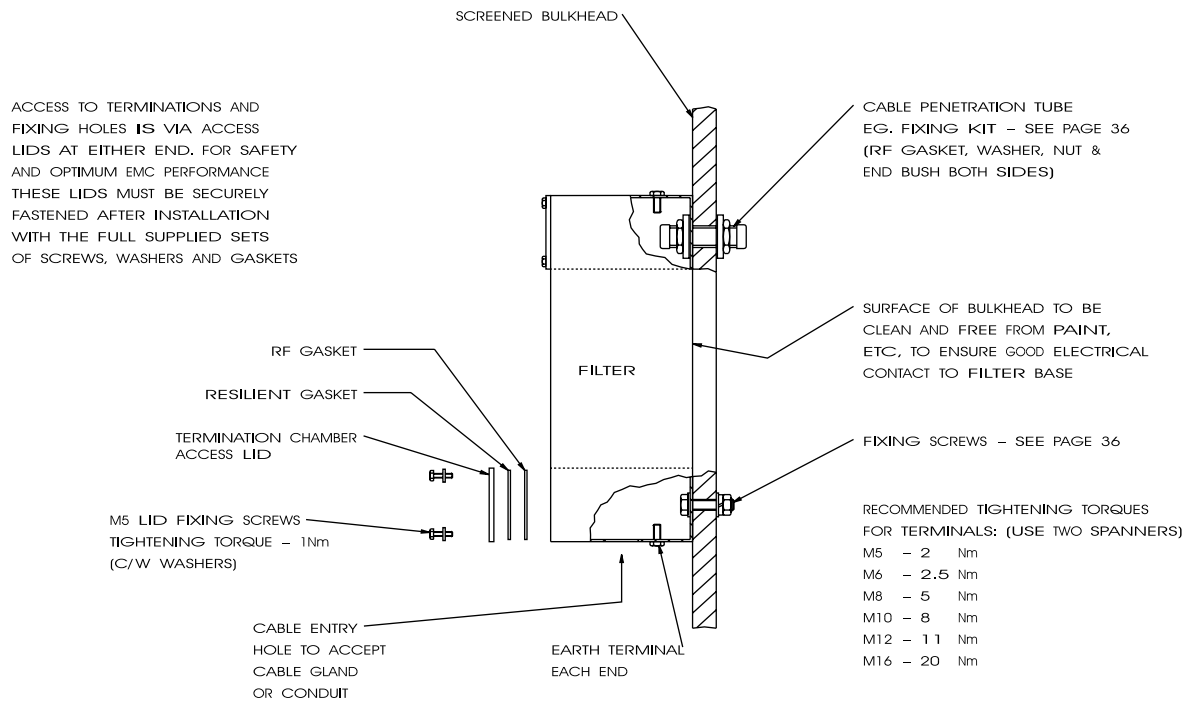

## Cable Entry Options

The following standard cable entry hole positions are available on all rectangular filters with terminal compartments. The required cable entry is simply specified by adding the appropriate suffix to the filter part number as shown below. Other cable entries can be provided to special order.

Suffix "C" denotes the standard version and this type will be supplied in the event of no cable entry suffix being specified.

**Note:** Transient suppressors, where fitted, are always on the input end of the filter.

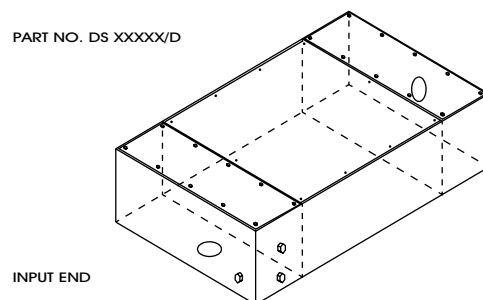
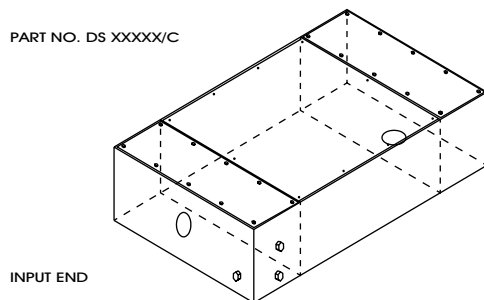
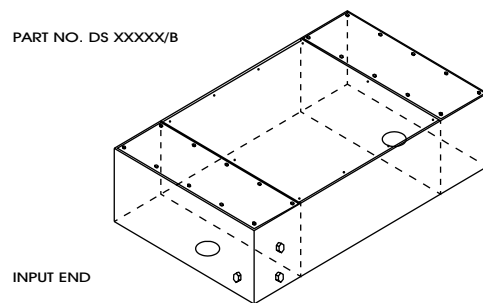
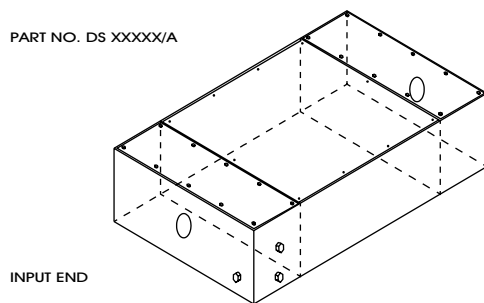

# Outline Dimensions

Dimensions are tabulated below for rectangular style filters. They apply to the standard cable entry style. (i.e. suffix C on filter part number - see page 37)

All dimensions are given in mm.

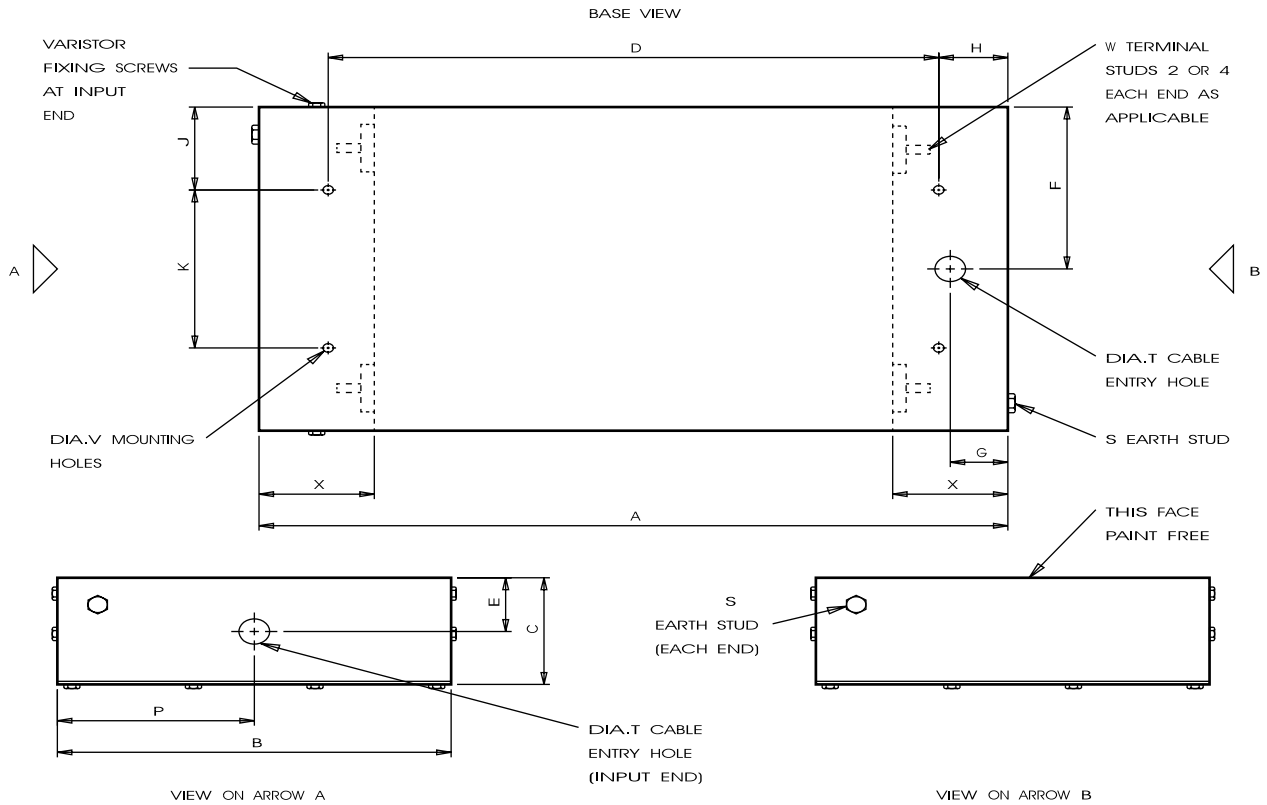

Normal configuration is for the neutral terminal to be adjacent to the earth terminal at the supply end of the filter.

CASE SIZE	Table of Dimensions (mm)															
	A	B	C	D	E	F	G	H	J	K	P	S	T	V	W	X
a	310	175	90	212	45	88	35	49	24	127	88	M6	20	9	M5	65
b	310	350	90	212	45	175	35	49	67	216	175	M6	25	9	M5	65
c	425	175	90	327	45	88	45	49	24	127	88	M6	20	9	M5	85
d	425	350	90	327	45	175	45	49	67	216	175	M6	25	9	M5	85
e	550	205	95	487	48	103	45	31	61	83	103	M10	32	9	M8	85
f	550	205	105	487	48	103	45	31	61	83	103	M10	32	9	M8	85
g	550	410	95	487	48	205	45	31	62	286	205	M10	32	9	M8	85
h	550	410	110	487	48	205	45	31	62	286	205	M10	32	9	M8	110
i	640	205	120	537	48	103	65	52	61	83	103	M10	32	9	M8	110
j	660	410	135	537	68	205	75	62	62	286	205	M10	32	9	M8	120
k	725	175	90	627	45	88	45	49	24	127	88	M6	20	9	M5	85
l	725	205	105	621	48	103	55	52	61	83	103	M10	32	9	M8	110

CASE SIZE	Table of Dimensions (mm)															
	A	B	C	D	E	F	G	H	J	K	P	S	T	V	W	X
m	725	410	110	663	48	205	55	31	62	286	205	M10	32	9	M8	110
n	760	205	120	656	48	103	55	52	61	83	103	M10	32	9	M8	110
p	780	410	135	656	68	205	60	62	62	286	205	M10	32	9	M8	120
q	820	350	120	710	60	175	55	55	110	130	175	M10	32	13	M8	110
r	970	350	120	860	60	175	55	55	110	130	175	M10	32	13	M8	110
s	1206	350	150	1130	75	175	60	38	110	130	175	M10	32	13	M8	120
t	1206	573	162	1130	81	286	75	38	110	353	286	M12	51	13	M12	135
u	660	475	135	537	68	238	60	62	110	255	238	M12	51	13	M12	120
v	660	575	150	537	75	288	60	62	110	355	288	M12	51	13	M12	120
w	590	410	95	527	48	205	45	31	62	286	205	M10	32	9	M8	85
x	820	475	150	680	75	238	70	70	110	255	238	M12	51	13	M12	140
y	820	575	150	680	75	288	70	70	110	355	288	M12	51	13	M12	140
z	1750	650	180	1260	90	325	75	245	150	350	325	M20	63	17	M20	300
aa	725	350	95	635	47	175	45	45	85	180	175	M6	20	9	M5	85
bb	725	350	95	635	47	175	45	45	85	180	175	M6	20	9	M5	85
cc	820	700	120	710	60	350	55	55	175	350	350	M10	32	13	M8	110
dd	970	700	150	860	75	350	55	55	175	350	350	M10	32	13	M8	110
ee	1206	700	162	1086	81	350	60	60	175	350	350	M10	32	17	M8	120
ff	1206	930	172	1070	85	465	68	68	230	470	465	M12	51	17	M12	135
gg	1750	1000	180	1260	90	500	75	245	250	500	500	M20	75	17	M20	300
hh	600	100	90	540	45	50	30	30	20	60	50	M6	20	9	M5	65
ii	700	130	110	640	55	65	30	30	30	70	65	M10	25	13	M8	65
jj	850	130	110	770	55	65	40	40	30	70	65	M10	25	13	M8	85
kk	1000	160	130	870	65	80	65	65	30	100	80	M10	32	13	M8	130
ll	1200	200	150	1070	75	100	65	65	40	120	100	M12	51	17	M12	130
mm	1250	475	150	760	75	238	75	245	110	255	238	M20	63	17	M20	300
nn	1250	575	150	760	75	288	75	245	110	355	288	M20	75	17	M20	300
pp	750	500	160	620	80	250	60	65	130	240	250	M12	40	13	M12	120
qq	1050	525	185	660	93	263	60	195	130	265	263	M20	51	13	M20	250
rr	750	700	170	620	85	350	60	65	150	400	350	M12	51	13	M12	120
ss	1700	700	170	1210	85	350	75	245	150	400	350	M20	75	17	M20	300

## Custom Designs

The products detailed within this catalogue comprise one of the most comprehensive ranges of power line filters currently available, and should fulfil most system requirements.

Whilst standard catalogue filters should always be specified as a preferred option, MPE recognise that there will inevitably be instances where non-standard filters are required. We are always prepared to offer specialist advice and guidance on custom solutions to specific EMC problems.

Some of the areas where we have previously helped our customers include:-

Modified filter circuitry to suit unusual terminating impedances.

Special filter circuitry to meet non-standard performance requirements.

Filters for supplies with high harmonic content.

Special voltage and current requirements.

High shock and vibration capability.

Reduced magnetic signature filters.

Customised mounting hardware.

Extended terminal compartments to suit oversize cables.

Special cable entry sizes and positions.

Interfaces to trunking and distribution boards.

To discuss your custom requirements with one of our filter engineers, please call our Technical Helpline.

**MPE Technical Helpline: +44 (0) 151 632 9199**

**MPE Sales: +44 (0) 151 632 9100**

**MPE Fax: +44 (0) 151 632 9112**

**MPE Web Site: [www.mpe.co.uk](http://www.mpe.co.uk)**

### STANDARD TERMS AND CONDITIONS

Except where the buyer is dealing as a consumer (as defined in section 12 of the Unfair Contract Terms Act 1977) all other warranties, conditions or terms relating to the quality and/or fitness for purpose, merchantability or condition of the goods and/or supply of the services and whether implied by statute or common law or made expressly whether by us or our servants or agents or otherwise are excluded to the fullest extent permitted by law.

Except in relation to death or personal injury caused by our negligence, we shall not be liable by reason of any representation or any implied warranty, condition or other term, or any duty at common law, or under any express terms, for any indirect or consequential loss or damage (including loss of profits), costs, expenses or other claims for consequential loss whatsoever (and whether caused by the negligence by us, our employees or agents or otherwise) which arise out of or in connection with the supply of the goods and/or services or the use or resale of the goods by the buyer or arising from any breach or failure, direct or indirect, on the buyer's part under the terms of the contract.